

# Environmental Dredging Pilot Study Successfully Completed on the Lower Passaic River, NJ –

One of America's Most Polluted Rivers

Lisa A. Baron<sup>1</sup>, Maheyar R. Bilimoria, PhD<sup>2</sup>, Scott E. Thompson, PE<sup>3</sup>

PULLOUT

**N**ew Jersey Department of Transportation, Office of Maritime Resources (NJD-OT), US Environmental Protection Agency (USEPA) and the US Army Corps of Engineers (USACE) completed an *Environmental Dredging and Sediment Decontamination Technology Pilot Study* during frigid weather in December 2005 in an estuarine environment with complex circulation patterns - one of the very few conducted during an ongoing feasibility study.

The partner agencies will use the site-specific results of the pilot to evaluate sediment removal and treatment as one remedial alternative for cleaning up and restoring the Lower Passaic River.

#### The major objectives of the Pilot include:

- \* Evaluate dredging equipment performance. This includes productivity, precision (achieving targeted dredging depth and cut lines), turbidity levels, and operational controls.

- \* Monitor sediment resuspension. This includes determining how much sediment is released from the dredging activity and where that sediment is transported. The monitoring program will help determine what kind of engi-



neering controls would be required for a full-scale sediment removal action.

- \* Evaluate sediment decontamination and treatability. The second part of the pilot will evaluate the technical feasibility and economic viability of two decontamination technologies to treat contaminated Passaic River sediments at full scale and determine whether a valuable product, such as manufactured soil or cement, can be produced.

#### Pilot Study Planning

The partner agencies conducted an extensive data collection effort in preparation of implementation within the pilot study area. Studies included: environmental dredging technology review, hydrographic surveys, side-scan sonar, sub-bottom profiles, magnetometry and gradiometry surveys, sediment coring (to characterize chemical and geo-technical properties of the sediment), hydrodynamic studies and predictive plume modeling.

Detailed project plans for implementation included a work plan, a quality assurance project plan, and health and safety plans. All activities conducted in support of the environmental dredging pilot study are posted on [www.ourpassaic.org](http://www.ourpassaic.org).

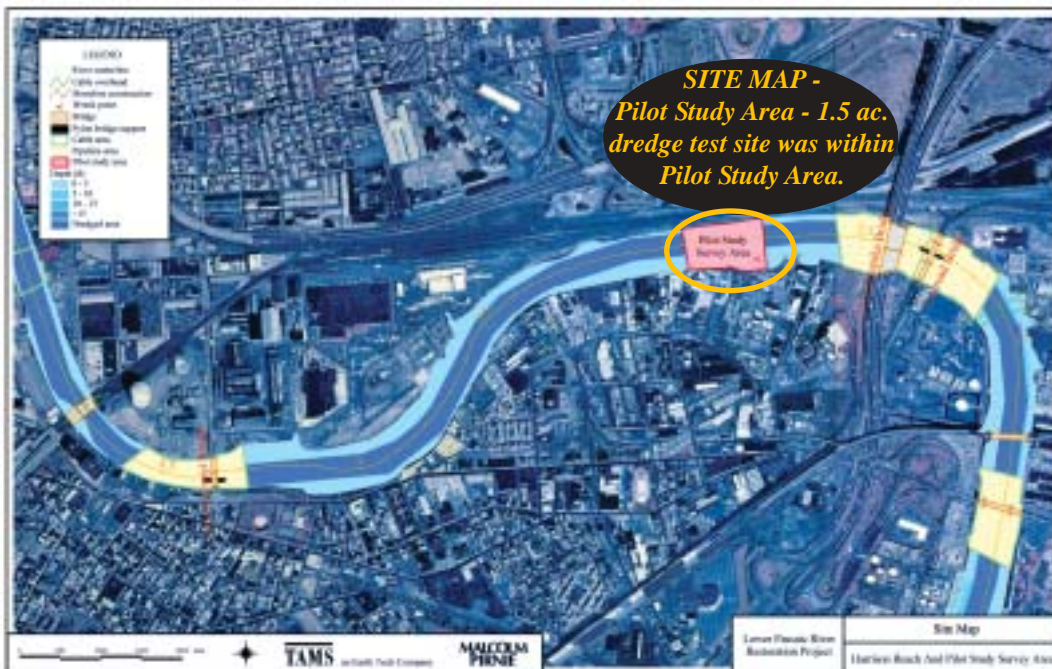



*Field crew composed of representatives from NJDOT, USACE, USFWS, USGS, Rutgers, TAMS/EarthTech, Inc., Malcolm Pirnie, Inc., and AquaSurvey, Inc.*

### Project Team

This Environmental Dredging Pilot Study was conducted by an unprecedented coordinated technical team composed of experts from multiple agencies, organizations, universities and consulting firms. The pilot was led and primarily funded by NJDOT, Office of Maritime Resources – the local sponsor for the overall Feasibility Study. The USACE provided vessels, field personnel, and dredging construction oversight. USEPA provided analytical services for water quality samples and critical partnership for the decontamination pilot.

US Fish and Wildlife Service (USFWS) provided a shuttle vessel and field staff, and US Geologic Survey (USGS) and Rutgers University led the water quality monitoring program. Our consultant team included Earthtech, Inc. (NJDOT's prime consultant) and Malcolm Pirnie, Inc., firms that provided the basis for the design, project specifications, and implementation of the program including dredging construction oversight with the multi-agency partnership. AquaSurvey, Inc. also conducted many of preparatory surveys and provided vessels and field personnel for pilot implementation.

NJDEP, Office of Dredging and Sediment Technology provided technical assistance and permits including the *Federal Consistency Determination and Water Quality Certificate*. In addition, Professor Donald Hayes from the University of Utah and Dr. Michael Palermo of Mike Palermo Consulting, world renowned technical experts were key advisors to the development of the *Environmental Dredging Pilot*.

Passaic Valley Sewage Commissioners (PVSC) located approx. 2.0 mi. downstream of the dredging site, provided daily access to their dock for vessel and equipment storage, loading of field crew and refrigerated storage of water quality samples.

Close to two years of planning were necessary to conduct the preparatory evaluations and activities leading up to implementation. The pilot team as mentioned above also held numerous work group meetings with all the partner agencies, environmental and community stakeholders and the Cooperating Parties Group (currently 43 Po-

tentially Responsible Parties). A tremendous amount of coordination was necessary for the integration of the dredging, materials handling and decontamination aspects of this program.

### Environmental Dredging Operation

Jay Cashman, Inc. working closely with Cable Arm Inc. was contracted by NJDOT as a result of a competitive prequalification process with selection based on cost and qualifications. There were significant challenges associated with the procurement process and fast-track project schedule. Despite these hurdles, NJDOT advertised, selected and contracted with Jay Cashman within a three month time frame.

Close to 5,000 yd<sup>3</sup> of contaminated sediment was dredged from the upper three feet of a 1.5 ac. area in the Harrison Reach just west of the New Jersey Turnpike Bridge. The dredge prism consisted of three cut lines approx. 300 ft long at elevations of 11 ft, 13 ft, and 15 ft below mean low water (MLW). The dredging was conducted in 10 to 15 ft of water at low tide.

Dredging was conducted within five days of operation. However, dredging was canceled on December 9<sup>th</sup> due to poor weather conditions (heavy snow, ice, and gale force winds) that impacted the water quality sampling program. Overall, dredging occurred at a rate of approx. 1000 yd<sup>3</sup> per 12-hr workday using an 8.0 yd<sup>3</sup> mechanical clamshell dredge bucket. The dredge bucket was specifically manufactured for this pilot study by Cable Arm, Inc.

The bucket was Equipped with *Clam-Vision* depth transducer (.001%) to ensure precision dredging to grade, Ross 835 depth penetration transducers to reduce overfilling of bucket, and bucket closure sensors to ensure bucket was sealed and closed prior to removal. The sys-



*Cable Arm Clamshell Bucket with overlapping sideplates (8.0 yd<sup>3</sup>)*

tem was also linked to *ClamVision* software.

The *ClamVision* displayed a 3D, color coded surface derived from existing hydrographic survey data. Each bite was recorded and color coded based on bite depth or bites left. An information box provided instant feedback showing current depth, final project depth, target depth, current bucket depth and an indication that the bucket was closed and sealed.

The dredging was executed in accordance with the contract plans and specifications issued by NJDOT. The design was prepared to test production-rate remedial dredging. The specifications required that dredging accuracy be achieved to +/- 6.0 in. tolerance.

The dredge was operated with a lift speed of approx. 2.0 ft / sec. through the water column. A rinse tank was used to clean the dredge between each cycle.

Numerous variables, and their effects on sediment resuspension and transport, were tested during the study, including:

- \* Dredging cycle time;
- \* Depth positioning technique (depth transducers vs. the measuring chain);
- \* Equilibration holding time; and
- \* Number of lifts per dredging area.

### Resuspension Monitoring Program

One of the primary goals of this pilot study was to measure the amount of sediment that is resuspended and subsequently transported downstream as a result of a dredging operation in the **Passaic River estuary**.

The comprehensive and elaborate resuspension monitoring program utilized a combination of six fixed moorings as well as shipboard monitoring using four boats.

Prior to execution of the study, a focused three dimensional hydrodynamic and sediment transport model using **Computational**



*Cable Arm Bucket and Rinse Tank.*

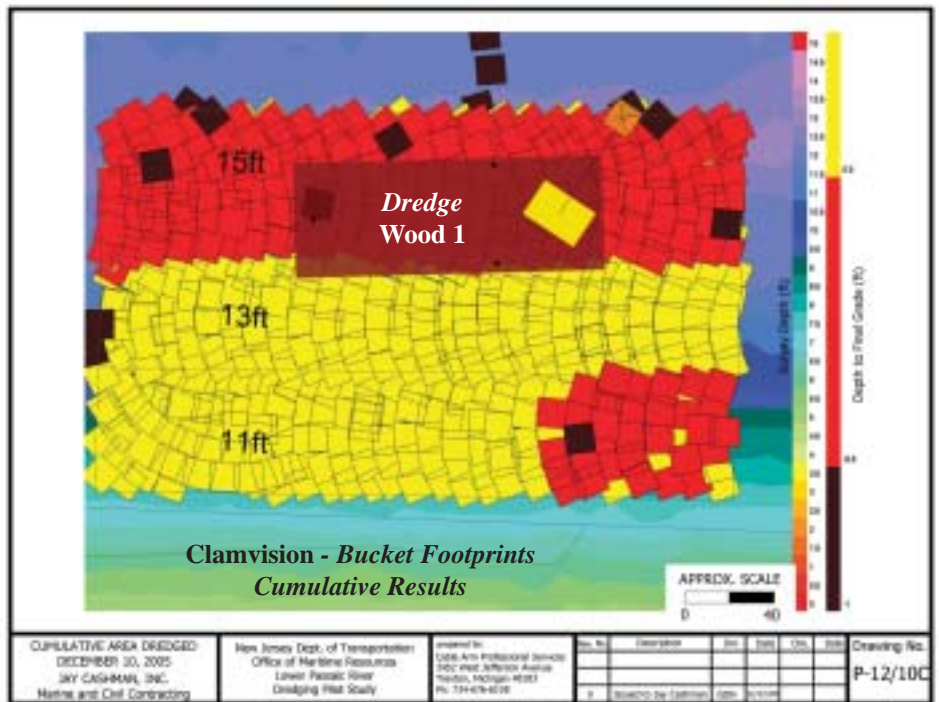

**Fluid Dynamics(CFD)** was developed to determine the best locations for positioning of water column monitoring equipment, to estimate the mass flux of sediment leaving the study area, and to evaluate the impact of dredging without engineering controls.

The water quality monitoring program was initiated on November 30, 2005, five days prior to dredging. The

### Monitoring Mooring Arrangement with Monitoring Boat Track (Plan View) Ebb Tide

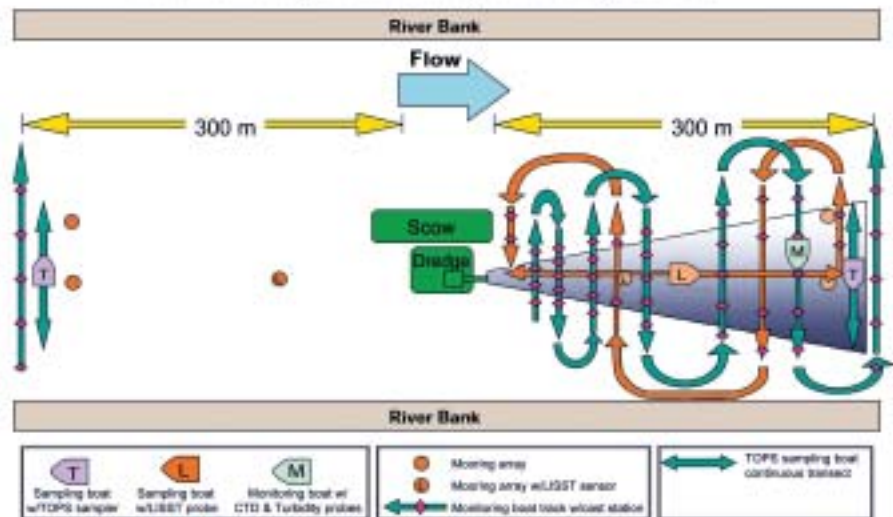

team conducted a dry run mimicking the sampling program; practicing sample collection; coordinating six vessels, communication, and shuttling and transfer of equipment and personnel between boats.

Background water quality samples (pre-dredge monitoring) were collected and the six moorings were deployed on December 1, 2005. Additional background water quality samples (post dredge monitoring) and mooring retrieval was completed December 12.

Four of the six moorings were located along the centerline of the targeted dredge prism (two upriver and two downriver of the dredging operation). Based on model

predictions that the plume follows the path of deeper water conveyance, the remaining two moorings were located in the deepest portion of the navigation channel at the same distance (at approximately 300 m) as the outermost centerline moorings (closer to the northern bank – one on either side of the dredging operation).

Each mooring, consisting of a float at the water surface and an anchor and a tripod frame suspended on a chain, was equipped with two **Conductivity-Temperature-Depth (CTD)** probes, two **Optical Back Scatter (OBS)** sensors, and an **Acoustic Doppler Current Profiler (ADCP)**.

In addition to the above instruments, the two centerline moorings closest to the targeted dredge prism (at approx. 120 m) were each equipped with a **Laser In-Situ Scattering and Transmissometry (LISST)** probe. The moorings monitored water column stratification and stability, particle concentration and size distribution on a 24-hr-basis throughout the project.

Two of the four boats, each equipped with a global positioning system (GPS), a depth profiler, a **Trace Organic Platform Sampler (TOPS)** apparatus and two ISCO automatic samplers performed continuous traverses perpendicular to the river flow at half-hour intervals along the outermost upriver and downriver moorings.

These USGS led vessels collected water samples for **total suspended solids (TSS)**, particulate and dissolved organic carbon, chloride/bromide, and for both filtered and unfiltered metals, low level mercury, dioxins/furans, PCB congeners, and pesticides analyses. The sediment load will be evaluated by comparing TSS and contaminant concentrations downstream to background TSS and contaminant concentrations measured upstream.

A third boat (led by Rutgers University), equipped with a CTD probe, an OBS sensor, and an ADCP, conducted sweeps across the near-field plume in a zig-zag pattern crossing the plume approximately seven times in approximately one hour. The fourth boat (also led by Rutgers) equipped with a CTD probe, a LISST probe, and an OBS sensor, ran along the centerline of the plume parallel to the flow.

To a limited extent, this fourth boat also moved in a zig-zag pattern to identify the edges of the plume. TSS samples were collected throughout the five-day study to calibrate the direct reading instruments. These two boats also monitored upstream to measure background concentrations.

The shuttle vessel made several daily trips between PVSC's dock and the Pilot Study's command vessel (USACE's SUV Hudson), the four sampling vessels and the dredge. The shuttle vessel's principal purpose was to transfer personnel, equipment and supplies, samples for processing, and hot beverages and food daily.

The sampling teams remarked how the delivery of hot food and beverages through the day were critical for keeping morale high during long hours in brutal wintery conditions.



*Real Time Plume Tracking.*

### **Residuals Monitoring- Sediment Profile Imagery**

The *Pilot Study* also intends to qualitatively evaluate residuals within the dredging area. The contamination in the Passaic River increases at depth and achieving a cleanup standard was not a factor for the pilot. Therefore, **Sediment Profile Imagery (SPI)** was used as a method to visually identify the depth of residuals inside the dredging area and immediately downriver and downslope.

A total of 15 SPI pictures (nine within the dredging area, two upstream, two in channel downslope and two downstream) were taken on December 13, 2005. Additional SPI evaluations will be conducted six months following dredging to determine the re-establishment of the benthic community in the area.

### **Sediment Decontamination Technology Pilot**

The specific goals of the sediment decontamination technology pilot study are to demonstrate that contaminated sediment from the Lower Passaic River can be handled safely, decontaminated effectively and be used to manufacture beneficial use products such as cement and soil.

Environmental and economic data, as well as experiences gained through the pilot study, will greatly improve the partner agencies' ability to potentially apply sediment treatment technologies on a larger scale in future sediment cleanup efforts in the Lower Passaic River.

Following dredging, the sediment was transported in two SI 3000 scows to the **Bayshore Recycling Inc. (Bayshore)** facility located on the **Raritan River in Keasbey, NJ**. There the sediment was off-loaded to the *Valgocen*, a 730-ft bulk carrier vessel owned by Bayshore.

The *Valgocen* will serve as a temporary storage location for the dredged sediments, as well as a materials handling facility. This winter, the sediment will be removed from the *Valgocen* and subjected to two different sediment decontamination technologies, both of which are currently undergoing testing through the USEPA/NJDOT New York/New Jersey *Sediment Decontamination Program* and USEPA's *SITE program*.

### **Sediment Washing Technology Evaluation**

During a one-week period in January 2006, BioGenesis

Enterprises, Inc., will treat the Passaic river sediments using its patented sediment washing technology. BioGenesis strips contaminants (metals and organics) from sediment particles using a specially-developed biodegradable detergent and impact forces from high-pressure water jets. Manufactured soil is produced during the treatment process. The soil could be used in a number of land-based applications, such as upland remediation and landscaping.

### Thermal Destruction Technology Evaluation

In 2006, Endesco Clean Harbors will treat the remainder of the Passaic River sediment using its patented Cement-Lock thermal destruction technology. This treatment process will be implemented at the International-Matex Tank Terminal in Bayonne, NJ. The Cement-Lock thermal destruction technology uses a rotary kiln operating at temperatures up to 2600 F and proprietary modifiers to completely melt the sediment.

The molten mixture is rapidly cooled to immobilize inorganic contaminants. The result is a glassy, granular material called ecomelt. The ecomelt is ground and blended with Portland cement to produce construction grade blended cement. The cement could potentially be used in the construction of sidewalks, parking lots and driveways. The process is equipped with pollution control equipment that is able to continuously remove potential pollutants from the system's emissions.

### Conclusions

The Environmental Dredging and Sediment Decontamination Technology Pilot Study will provide valuable site-specific information in order to evaluate the removal option as a potential remedial solution for the Feasibility Study.

The Environmental Dredging Pilot Study was successfully completed between November 30 and December 13, 2005. The results of the dredging operations, resuspension



*Sediment transported to Bayshore*

monitoring program, and decontamination technology evaluation will be the subject of future technical publications. Stay tuned!!

### Acknowledgements

Although there are only three co-authors (the Project Managers), there are dozens of individuals that were integral to the success of this pilot. Special thanks to the Pilot team that included: Rick Gimello, Mike Riley, Scott Douglas (NJDOT), Peter Weppeler, Mike Marcello, Michael McGuire, Mark Kucera, Shewen Bian, Ron Conetta, Steve Weinberg, Tim LaFontaine, Peter Shugert, Scott Nicholson, Carolyn Vadino (USACE), Alice Yeh, Eric Stern, Jennifer Ferranda, John Birri, David Kluesner (USEPA), Tim Wilson, Jennifer Bonin, Nicholas Smith (USGS), Robert Chant, Chip Haldeman, Dave Fugate, Eli Hunter, Dan Crowell, John Zlotnik (Rutgers), Lisa Swan, Celeste Foster, Paul Kareth, Allen Burton, John Rollino, Robert Forstner, Sameer Ahsan, Amit Haryani, Roman Senyk, April Thomann, Edward Sitler, John Szeligowski, Muhammad Akbar, Florence Rollino, Ryan Edison, Serkan Mahmutoglu (TAMS/EarthTech), Ed Garvey, Chris Purkiss, Erika Zamek, Liam Bossi, David Foster, John Peake, David Lewitt, John Mulligan, Jason Fuller, Jermaine Perry, Len Warner, Andrew Schell, Solomon Gbondo-Tugbawa (Malcolm Pirnie), Gene Nieminen, Richard Henry, Tim Kubiak (USFWS), Jim Nickels, Leonard Mangiaracina, Ken Hayes, Tom Dolce, Dave Morgan, Jim Todd (Aqua-Survey), Bob DeVita, Sheldon Lipke, Brian Davenport (PVSC), Janine MacGregor, Suzanne Dietrick, Dave Risilia (NJDEP), Don Hayes (University of Utah) and Mike Palermo (Mike Palermo Consulting).

Additional recognition to the Dredging Team including: Steve Radel, Bruce Wood, Richie Barber, Mike Lewis, Anthony Kerley, Anthony Carbone, Harry Ellis, Carl Stewart, Jimmy Bauer, Dan Gaudet (Jay Cashman, Inc), Bobby DeCrescenzo (Sterling Equipment), and Ray Bergeron, Sam Harrell, Darrell Nicholas, John Lajeunesse, Connie Boris, Gerald Swain and Harry Steves (Cable Arm, Inc).

Thanks to John Sontag (BioGenesis), Mike Mensinger (Endesco Clean Harbors), and Valerie and Frank Montecalvo (Bays-hore Recycling) for materials handling and decontamination of the sediment. Thank you all!

*Real Time Plume  
Tracking  
downstream of  
dredging activities.*



**Contact Information**

For more information visit the project Web site at [www.ourpassaic.org](http://www.ourpassaic.org) or contact:

**Environmental Dredging Pilot:**

**Lisa Baron**, Project Manager, Office of Maritime Resources: [lisa.baron@dot.state.nj.us](mailto:lisa.baron@dot.state.nj.us)

**Sediment Decontamination Pilot:**

- **Eric Stern**, Regional Contaminated Sediment Program Manager, USEPA: [stern.eric@epa.gov](mailto:stern.eric@epa.gov);
- **Scott Douglas**, Project Manager, Office of Maritime Resources, NJDOT: [scott.douglas@dot.state.nj.us](mailto:scott.douglas@dot.state.nj.us)

**General**

**Information about the Lower Passaic River Restoration Project:**

- **Scott Nicholson**, Project Manager, USACE: [scott.r.nicholson@nan02.usace.army.mil](mailto:scott.r.nicholson@nan02.usace.army.mil);
- **Alice Yeh**, Project Manager, USEPA: [yeh.alice@epa.gov](mailto:yeh.alice@epa.gov);
- **Lisa Baron**, Project Manager, Office of Maritime Resources, NJDOT: [lisa.baron@dot.state.nj.us](mailto:lisa.baron@dot.state.nj.us)



*December 9th, dredging suspended due to weather conditions*

**Dredging and Decontamination Technology Firms**

- Jay Cashman Inc., Bruce Wood: [bwood@jaycashman.com](mailto:bwood@jaycashman.com);
- Cable Arm, Inc., Ray Bergeron: [info@cablearm.com](mailto:info@cablearm.com);
- BioGenesis Enterprises, Inc., Charles Wilde: [cwilde@biogenesis.com](mailto:cwilde@biogenesis.com)
- Endesco Clean Harbor, Mike Mensinger: [Mike.Mensingergastech.org](mailto:Mike.Mensingergastech.org)

- (1) New Jersey DOT, Office of Maritime Resource, Trenton, New Jersey
- (2) Earth Tech Inc., Bloomfield, New Jersey
- (3) Malcolm Pirnie, Inc., White Plains, New York ○

